



# HYDRAULIC QUICK HITCH

## Installation & Operation Manual

**Important: This manual must be kept with the excavator at all times  
and referred to as required**



Harford Attachments Ltd

## Table of Contents

Introduction	Harford Uni-Lok quick hitch for excavators	Page 2
Introduction	Safety features	Page 2
Installation	Fitting the quick hitch to the excavator	Page 3
Installation	Fitting the hydraulic components	Page 4
Installation	Fitting the electrical components	Page 6
Safe Operation	Connecting an attachment	Page 7
Safe Operation	Releasing an attachment	Page 9
Safe Operation	Lifting a Load	Page 9
Maintenance	Daily checks	Page 10
Warranty	Earthmoving attachment	Page 11
Item Checklist	Hydraulic Uni-Lok quick hitch	Page 11
Appendix 1	Hydraulic and Electrical circuit	Page 12
Appendix 2	EC Declaration of Conformity	Page 13

If at any time in the future, you require additional information on the **HARFORD UNI-LOK** quick hitch or any aspects of its use, please do not hesitate to contact:

**Harford Attachments Ltd**

Spar Road, Norwich. NR6 6BY. England

Tel +44 (0) 1603 403099

Fax +44 (0) 1603 402399

**email: [info@harfordattachments.co.uk](mailto:info@harfordattachments.co.uk)**

**website: [www.harfordattachments.co.uk](http://www.harfordattachments.co.uk)**

## Introduction

### Harford Uni-Lok quick hitch for excavators

Thank you for choosing to purchase the **Harford Uni-Lok** quick hitch for excavators. The information contained in this manual should be thoroughly read and understood by all operators of this quick hitch.

The Uni-Lok is a double-locking automatic quick hitch designed to pick up attachments manufactured to the OEM specification. The rear sliding wedge plate provides the primary locking device.

Due to the large number of excavator makes and models available worldwide, it is not possible to provide a rigid set of installation instructions that will cover every situation. It is, therefore, extremely important that the installation be carried out by properly skilled persons, preferably with past quick hitch installation experience.

It is essential that the operation and maintenance instructions are followed carefully to ensure safe and reliable operation of the quick hitch at all times. Failure to do so could result in serious injury and invalidate warranties.

This manual contains the installation and operation instructions for the Uni-Lok quick hitch. If the quick hitch you are about to fit or operate is not the Uni-Lok, please refer to the separate manual.

## Safety Features

There are several safety features that are incorporated into this quick hitch. Each feature further removes the possibility of the attachment unintentionally becoming disengaged.

1. Pilot operated check valve.  
This is incorporated into the double acting hydraulic cylinder.  
The attachment should remain locked due to a loss of hydraulic pressure.
2. Sprung loaded rear lock.  
This ensures that a force is still maintained on the rear locking wedge due to a loss of hydraulic pressure.
3. Rear lock indicator bar.  
This allows the operator to check that the rear locking wedge is in its correct operating position.  
This is visible from the cab.
4. Sprung loaded front lock.  
This ensures that the front pin is secure when connecting an attachment and during operation.  
This is visible from the cab.
5. Dual switching arrangement.  
The primary switch is a 'locked off' type to secure against inadvertent activation.  
The secondary switch is a 'momentary' type so that the attachment can only be released when it is pressed.

## Installation

### Fitting the quick hitch to the excavator



#### **SAFETY NOTICE:**

It is recommended that safety gloves are worn during the installation of the quick hitch.

1. Remove any existing attachment from the machine dipper arm and crowd link arm. The two original pins that are removed from these pivot points must be used to attach the quick hitch to the excavator (These pins are usually hardened and have greasing facilities).
2. Carefully align the dipper arm between the two front bosses on the hitch as shown by diagram 1. Replace any 'O' rings that were removed previously and slide one of the original pins through the quick hitch and dipper arm. Securely fix the pin in place by using the original or supplied retention method.
3. Repeat step 2 with the crowd link arm linkage.
4. Grease the two pins and visually check that they are located and secured correctly.
5. Use the excavator hydraulics to carefully rotate the quick hitch to the extremes of the crowd cylinder (e.g. no stroke and full stroke). Check the clearance of the quick hitch with any part of the dipper arm and linkage.
6. Fit the supplied yellow warning sticker in the cab in a prominent position. Also supplied are three 'safety pin not required' stickers – one to be fitted in the cab in a prominent position and one each side of the dipper arm near to the quick hitch.
7. Medium tensile pins (or better) should be used in both pin location holes of the attachment. Visually check to ensure the pins are correctly fitted and are secure before the attachment is used. Ensure any retention bolts are tightened using double nuts to lock against each other.

**Diagram 1**

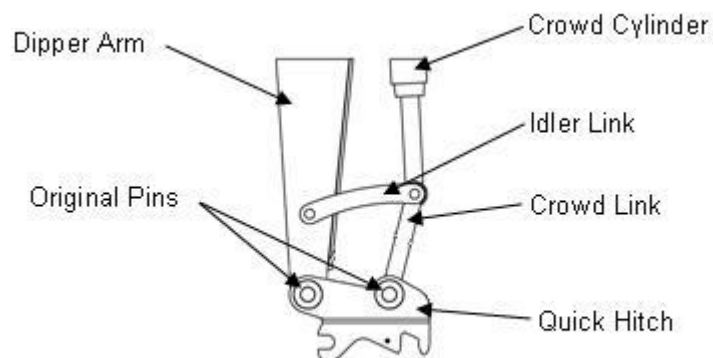

## Installation

### Fitting the hydraulic components.



#### **IMPORTANT:**

To install this quick hitch requires a solenoid valve, pressure switch, hoses and fittings. The Harford fitting kit consists of these components. This quick hitch has been designed to operate at the excavator's maximum working pressure. If this is more than the hydraulic cylinders maximum pressure (stamped on top) a pressure reducing valve must be fitted. All components must be the correct specification and be installed by skilled and suitably experienced persons.



#### **WARNING:**

Before doing any welding and work on the electrics of the machine, ensure that battery has been disconnected to prevent damage to the machine circuit.

### Manifold block

1. The excavator geometry will determine where the manifold block should be placed
2. It should be welded as low down the dipper arm as possible on either the top or sides as shown by the photos below.
3. Ensure it is positioned so that when the hoses are fitted they are not too long, overstretched or impeded by the quick hitch or links during operation.



### P Clips

1. Fit P-Clips & spiral wrap as shown below.
2. Ensure that the hoses are not overstretched.



## Installation

### Solenoid Valve



#### **WARNING:**

Ensure that the solenoid valve is not energised when the quick hitch is in the locked position. This will ensure the coil will not burn out and will also ensure that in the event of an electrical failure, the quick hitch will stay in the locked position.

1. Ensure that you about to fit the correct Solenoid valve. For cylinders rated 3500 and 4000 PSI fit the 'Delta' Solenoid valve and the cylinder rated at 5000 PSI fit the 'Hydac' Solenoid valve.
2. Position solenoid valve in a safe, dry area close to the hydraulic pump, or main valve assembly.
3. The solenoid valve must be connected to the main pressure line of the excavator between the pump and main control valve. It is recommended that the main test port is used.
4. Ensure fixing bolts are tightened.

### Pressure Switch



#### **IMPORTANT:**

This switch has been factory set so that it operates when the pressure reaches 150 bar (2175 psi) but it can be adjusted between 100-250 bar (1450–3625 psi).

1. Ensure that the pressure switch is fitted into the bucket extend line.

### Hydraulic hoses



#### **WARNING:**

Hydraulic oil pressure and fluid can cause serious personal injury. When escaping under pressure it can penetrate body tissue, cause severe tissue damage, loss of limb and possible death. Always check for leaks with the use of a shield and not against any part of your skin. Alternatively shut off the pressure and allow time to de-pressurize. If fluid is injected into your skin you must seek emergency treatment straight away by medical personnel that have knowledge of this kind of injury. Remember some hydraulic fluids are also flammable. Refer to relevant COSHH data sheets for substances that you may come into contact with.

1. Ensure all hydraulic components are suitable for the working pressure.
2. The hydraulic components must be piped according to the relevant circuit as shown on appendix 1.
3. Weld pipe clamps to the excavator arms to retain hose at appropriate positions, hydraulic hoses should follow the paths of existing hydraulic lines of the excavator. Disconnect the negative/earth lead from the battery prior to any welding operation. Remove paint from the weld area prior to welding and use anti-spatter to protect the arm. Protect hydraulic rams and any existing hoses from weld spatter.
4. Cut and fit hose protector where applicable especially where hoses attach to the hydraulic cylinder on the hitch.
5. Hydraulic hoses should be long enough to accomplish their intended function whilst ensuring that during operation the minimum bend radius stated by the hose manufacturer is adhered to. Allowance should be also made for changing characteristics of the hose under differing operating conditions.
6. Avoid contamination within the hydraulic circuit.

## Installation

7. If hoses are not pre-assembled ensure any assembly follows hose manufacturers recommendations.
8. Do not re-use old or damaged hose or fittings. If fittings come off during use, do not re-attach but replace the whole hose assembly.
9. Do not mix hydraulic hose and adaptors from different manufacturers and ensure all fittings used are compatible.
10. Ensure all connections are tightened to correct torque e.g. 1/4" BSP = 18Nm, 3/8" BSP = 31Nm.
11. Ensure any spillages are cleaned up.

### **IMPORTANT:**



The Harford hydraulic kit supplied conforms to EN 853-2SN. All hoses must be crimped by competent persons using the correct tooling. Further information can be obtained from Harford Attachments.

## Fitting the electrical components



### **IMPORTANT:**

To install this hitch requires a solenoid valve, pressure switch, relay, dual switch arrangement, warning buzzer, appropriate wiring and fuse. Our fitting kit consists of these components. All components must be the correct specification for the excavator and be installed by skilled and suitably experienced persons.

## Electrical wiring/switching

1. Ensure all electrical components are the correct voltage for the excavator.
2. The electrical components must be wired according to the switch circuit as shown on appendix 1.
3. The switches should be positioned in the cab within easy reach of the operator but not in a position so they can be inadvertently operated.
4. Ensure the warning buzzer is placed in a position so that it can be heard.



## Safe Operation



### **IMPORTANT**

This quick hitch is operated by a dual switch arrangement. A primary on/off lockable switch and a secondary momentary type.

### Connecting an attachment

- 1 Activate the primary switch .  to sound the warning buzzer and energise the secondary switch.
- 2 Fully extend the bucket cylinder and maintain operation of the control stick to ensure the pump works at full pressure as shown in diagram 2.
- 3 Press and release the secondary switch  to retract the rear locking wedge and open the front lock.
- 4 Lower the Quick hitch front 'C' shaped jaw down towards the front attachment pin ensuring the front lock is in the open position.
- 5 Engage the front jaw with the front attachment pin as shown by diagram 3.
- 6 Lift the attachment of the ground and then extend the bucket cylinder as shown in diagram 4.
- 7 De-activate the primary switch  to extend the rear locking wedge and close the front lock. The warning buzzer will turn off.
- 8 Retract the bucket cylinder slowly to view the indicator bar and front lock to ensure correct operating positions as shown by diagram 5. Conduct rattle test to confirm full engagement of the rear locking wedge.

**Diagram 2** - Extend the bucket cylinder

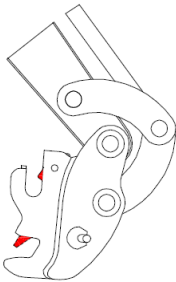

**Diagram 3** - Engage the front jaw

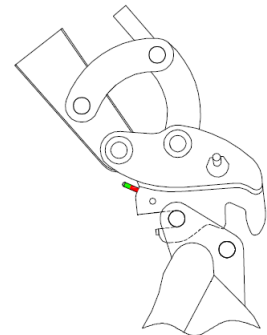

**Diagram 4** – Lift the attachment and then extend the bucket ram

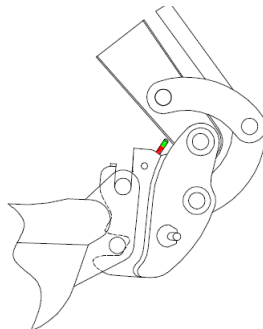



## Safe Operation

Diagram 5

Correct operating position

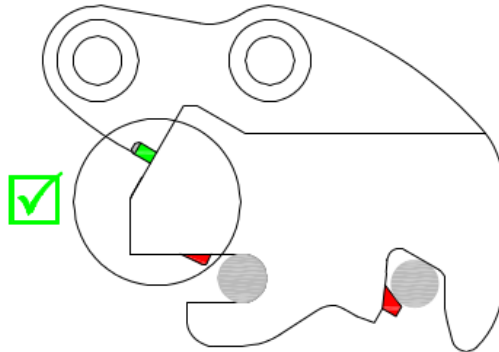

Incorrect operating position

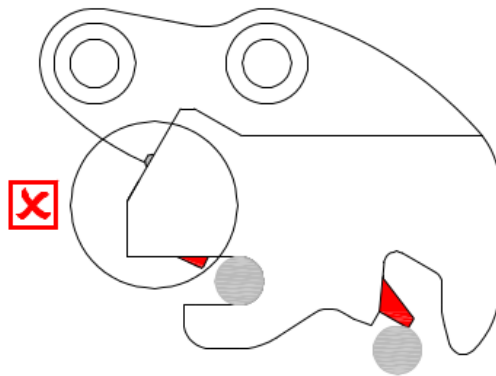

Incorrect operating position

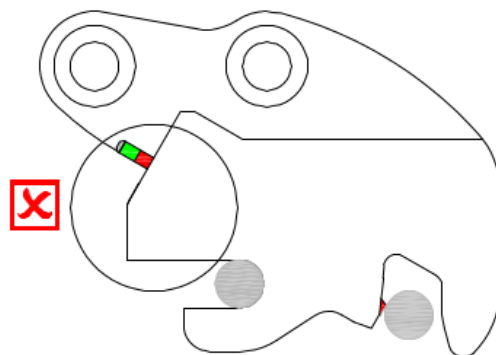

## Safe Operation



### **WARNING:**

During operation there should be no movement between the quick hitch and attachment. If any movement is detected, stop operation immediately, lower attachment to the ground and inspect the hitch.



### **WARNING:**

The quick hitch extends the length of the dipper arm and some attachments could hit the cab or boom in certain positions.



### **WARNING:**

The quick hitch is designed to accept attachments which are manufactured to OEM specifications and capacities. Oversized attachments could be hazardous when used with this quick hitch and could invalidate any warranties.



### **WARNING:**



Ensure the Safe Working Load of the excavator is not exceeded. Refer to the excavator manufacturer's information.



### **IMPORTANT:**

If hammers are to be used for long periods of time the quick hitch should be removed to prevent unnecessary wear.

## Releasing an attachment

- 1 Ensure people and property are well clear of the immediate area.
- 2 Activate the primary switch  to sound the warning buzzer and energize the secondary switch.
- 3 Extend the bucket cylinder fully and maintain operation of the control stick to ensure full pressure.
- 4 Press and release the secondary switch  to open the front lock and retract the rear locking wedge.
- 5 When the front lock is fully open carefully retract the bucket cylinder to disengage the attachment from the Quick hitch. Use the control sticks to position the dipper and boom to ensure the attachment doesn't fall to the ground.
- 6 De-activate the primary on/off switch  to turn off the warning buzzer.
- 7 The Quick hitch is now ready to connect another attachment.

## Lifting a load



### **IMPORTANT:**

This section only applies to quick hitches that are manufactured with a lifting eye.

1. Ensure that the load to be lifted does not exceed the safe working load of the lifting eye.
2. The lifting eye is designed to be used with a lifting shackle with the same safe working load rating.
3. Release the attachment from the quick hitch prior to using it to lift load.



### **IMPORTANT:**

Ensure the safe lifting capacity of the excavator is not exceeded. Refer to excavator manufacturer's information.

## Maintenance



### **WARNING:**

Hydraulic oil pressure and fluid can cause serious personal injury. When escaping under pressure can penetrate body tissue, cause severe tissue damage, loss of limb and possible death. Always check for leaks with the use of a shield and not against any part of your skin. If fluid is injected into your skin you must seek emergency treatment straight away by medical personnel that have knowledge of this kind of injury. Remember some hydraulic fluids are also flammable. Refer to relevant COSHH data sheets for substances that you may come into contact with.



### **SAFETY NOTICE:**

It is recommended that safety gloves are worn during the maintenance of the quick hitch.

### **Daily checks:**

1. Clean away any material build up around the front lock, cylinder, springs and wedge.
2. Grease wedge slide housing points
3. Check all pin retainers bolts & nuts for tightness on quick hitch and attachments
4. Check hydraulic hoses for damage, leakage or weeping, stiffness (as hose ages it can become stiff causing it to crack when flexed), blistering and general wear. Replace as required.
5. Check hose fittings at connection points for leaks, poor interfacing with hose or other connectors. Tighten and replace as required
6. Check quick hitch operation by connecting an attachment.
7. Check operation of warning buzzer.
8. Check quick hitch for evidence of wear, fatigue or weld failure.



### **IMPORTANT:**

Due to the self tightening and infinite wear feature accommodated with the hydraulic cylinder, if any attachment is fitted to the hitch for long periods of time it should be released daily. If the daily maintenance tasks are adhered to, this will happen automatically.



### **WARNING:**

If the quick hitch is damaged in any way and/or there is any doubt as to the continued safety please contact Harford Attachments Ltd, Technical Department on +44 (0)1603 403099.

## Warranty

### Earthmoving attachment

Harford Attachments Ltd (the seller) warrants their quick hitches as follows:

1. The seller shall repair or replace at the seller's option any of the goods which are, or which become, defective within 12 months from delivery due to faulty workmanship, materials or faulty design, provided that the buyer shall have notified the seller in writing of such defect and have given the seller a reasonable opportunity to inspect the defective goods.
2. If, in the opinion of the seller, the goods have not been operated or maintained in accordance with the instructions in this manual, or have been subject to unauthorised repair or modification, the warranty will be invalidated.
3. The seller's liability in respect of defects in the goods shall be limited to those stated in this clause and subject to Clause 2(1) of the **Unfair Contract Terms Act 1997**, the seller shall not be liable whether in contract or in tort, including but not limited to negligence, or by reason of breach of statutory duty or otherwise, for any damage or loss whatsoever suffered by the buyer arising out of or attributable to such defects.

### Item Checklist

The following items are supplied.

<u>Item</u>	<u>Supplied</u>
Hydraulic quick hitch	✓
Installation and operation manual	✓
Warning label	✓
Safety pin not required stickers	✓
Electrical fitting kit	<u>see note 1</u>
Hydraulic fitting kit	<u>see note 1</u>

#### Notes

1. The electrical and hydraulic kits are essential parts of the hydraulic quick hitch system but may not have been supplied by Harford Attachments Ltd.

### **Harford Attachments Ltd**

Spar Road, Norwich. NR6 6BY. England

Tel +44 (0) 1603 403099

Fax +44 (0) 1603 402399

**email: [info@harfordattachments.co.uk](mailto:info@harfordattachments.co.uk)**

**website: [www.harfordattachments.co.uk](http://www.harfordattachments.co.uk)**

## Appendix 2

Hydraulic Circuit  
(Delta Solenoid Valve)

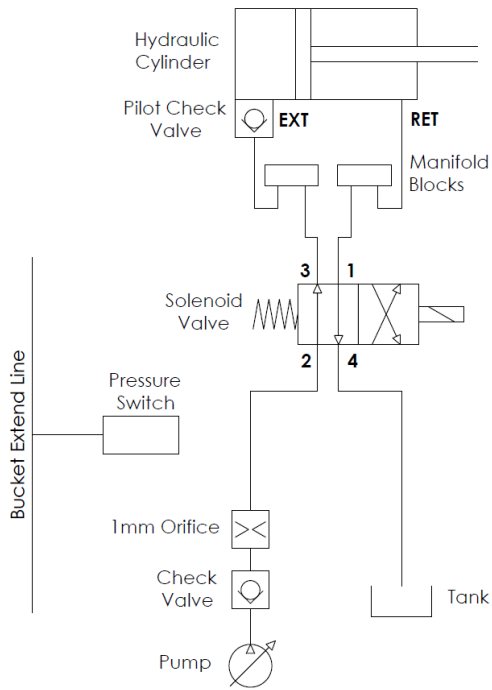

Hydraulic Circuit  
(Hydac High Pressure Solenoid Valve)

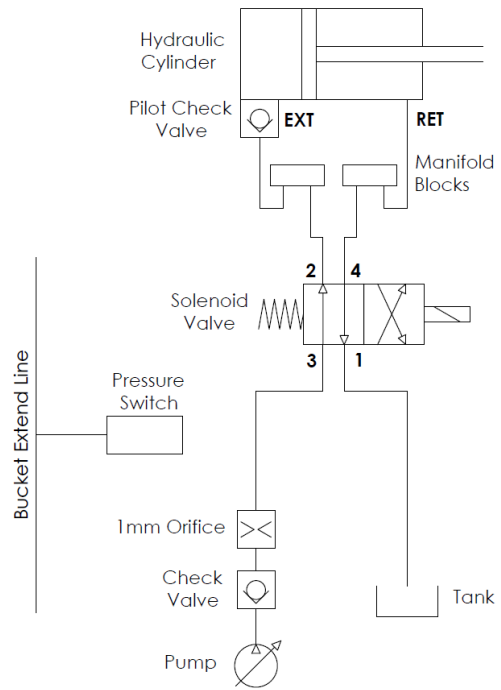

## Switch Circuit

